

Drive Electronics

for Stepper Motors

PRECiStep® Technology

For combination with:
PRECiStep 2-Phase Stepper Motors

Series AD xx M1S

xx =	VL	VM	CM	
	Voltage Mode	Voltage Mode	Current Mode	
Power supply voltage:				
- min.	3	6	10	V DC
- max.	14	24	28	V DC
Power supply current	14	14	13	mA
Output current, max. (for each phase)	500			mA
Logic input level:				
- low	0 ... 0,6			V DC
- high	1,6 ... 14	1,6 ... 24	1,6 ... 24	V DC
Direction of rotation	CW / CCW			
Step modes	full step / half step			
Step frequency:				
- min.	10 Hz ¹⁾	10 Hz ¹⁾	0 Hz ¹⁾	full step/s
- max.	2000 Hz ¹⁾	2000 Hz ¹⁾	6000 Hz ¹⁾	full step/s
Operating temperature range	0 ... +70			°C
Weight	22			g
Dimensions	76,3 x 53,5	76,3 x 53,5	83,2 x 53,5	mm

¹⁾ The clock signal must be provided by an external signal .

General description

The Drivers Series AD VL M1S, AD VM M1S and AD CM M1S have been designed for safe and simple operation for evaluation of all PRECiStep motors from ø6 to 22 mm.

The AD xx M1S versions are controlled by an external clock signal and a direction bit.

Voltage Mode Drivers

These drivers allow operating a step motor at low supply voltage (for example batteries). The motor phase current is not controlled by the driver. For that reason you need to use these drivers at the nominal voltage of the selected motor in voltage mode.

Please refer to the voltage mode performance curve in the motor datasheet to know the torque of the motor at your operational speed.

These drivers are recommended for all application operating below 10 V DC.

Current Mode Drivers

These drivers have an integrated phase current control circuit (chopper). The supply voltage can be selected much higher which increases the motor performance at higher operational speed.

Please refer to the current mode performance curve in the motor datasheet to know the torque of the motor at your operational speed.

This driver must be used above 10 V DC. It is recommended to use a higher voltage for increased performance.

Dimensional drawing

Scale reduced

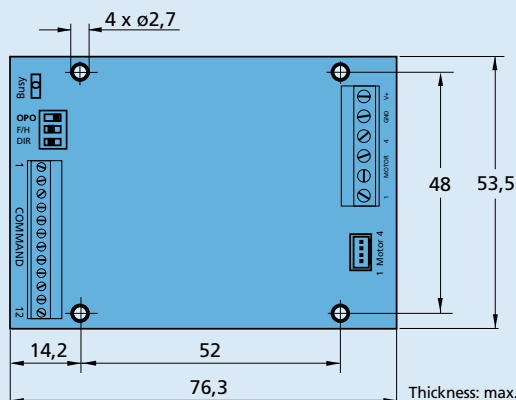

AD VL M1S, AD VM M1S

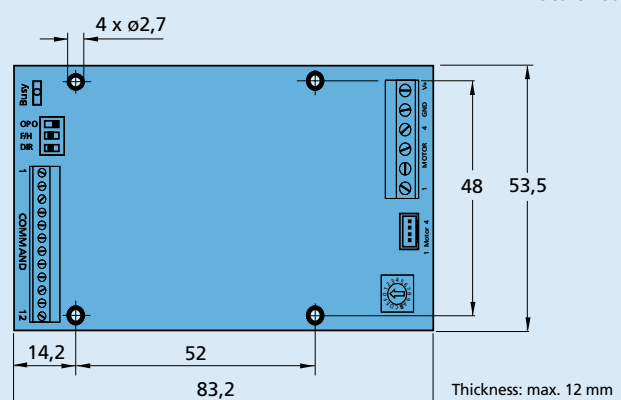

AD CM M1S

For Pin-Out of the command connector, please refer to page 2

Drive Electronics

for Stepper Motors

PREClstep® Technology

For combination with:
PREClstep 2-Phase Stepper Motors

Series AD xx M3S

The driver extension board, plugged into the M15 versions described on page 1, transforms the basic stepper motor driver with pulse and direction control into a stand-alone speed control driver AD xx M3S. The following control parameters can be set by the user by on board potentiometers:

- pull-in speed
- maximum speed
- acceleration rate
- deceleration rate

To execute the set speed profile, please refer to the graph, the control of START; STOP and DIR signals are sufficient.

All other functions and settings remain identical with the M15 versions.

The frequency range for the AD VM and AD VL is from 10 to 2000 Hz and for the AD CM from 0 to 6000 Hz.

Velocity profile example M3S

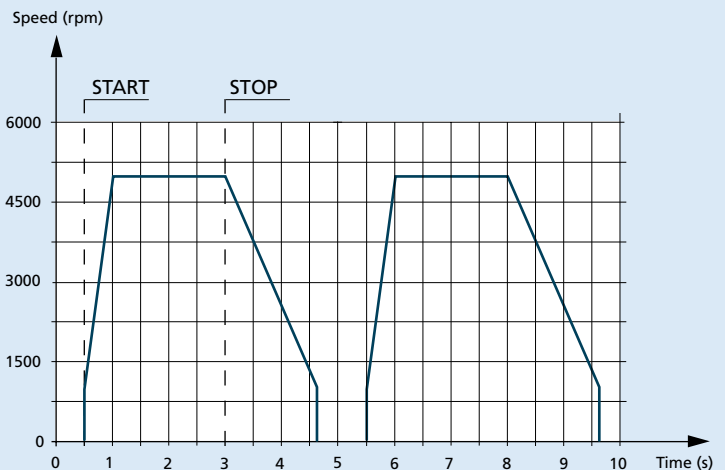

Connection information

Pin	I/O	Function	Description	M1	M3
1	I	OPO	Full-step; 1-phase ON (wave)	x	x
2	I	FS/HS	Full Step/Half Step mode switch	x	x
3	I	CCW/CW	Sense of rotation switch, default = CW	x	x
4	I	CLK	External clock input	x	x
5	I	RUN	Starts the clock generator		x
6	I	STOP	Stops the clock generator		x
7	I	STB	Current Standby	x	x
8	O	BUSY	Output = low when clock is active		x
9	I	BOOST	Current boost	x	x
10	N	VCC	+5V power supply	x	x
11	N	GND	Ground potential ≥ 0 Volt	x	x
12*	I	VCO	External control voltage for the oscillator		x
	O	HOME	Active when Phase A is commutated with positive current	x	

*Pin 12 can be switched as Input or output as described. Please refer to User Manual.

Dimensional drawing

Scale reduced

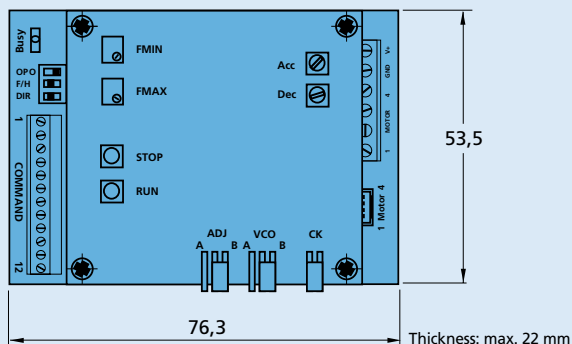

AD VL M3S, AD VM M3S

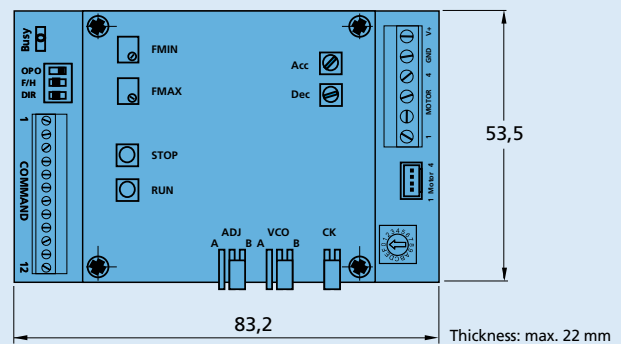

AD CM M3S